

# Axis<sup>AX</sup>

## Conventional Duct Detectors

The SL-2000 Series Smoke Duct Detector is the latest innovation for early detection of smoke and products of combustion present in air moving through HVAC ducts in Commercial, Industrial, and Residential applications. The unit is designed to prevent the recirculation or spread of smoke by air handling systems, fans, and blowers. Complete systems may be shut down in the event of smoke detection. The SL-2000 is designed and built to meet all local code requirements, as well as the NFPA and ICC standards regarding HVAC supply and return duct smoke detectors. Output terminals are provided for a wide range of remote accessories such as horns, strobes, remote status indicators, and test/reset key switches or push buttons.

The SL-2000 includes many features that represent true innovations from current generation duct smoke detectors. Our traditional installer/servicer-friendly approach has been closely followed and expanded throughout the SL-2000. This philosophy provides a new level of efficiency in after-purchase value to both the installer/servicer and end-user. Our attention to detail has yielded a host of “No-Tools Required” features, as well as a multi-application performance level as yet unmatched in the industry. Innovative product combined with unsurpassed customer service equals the right combination for all of your projects. The key features below detail many of the customer-driven innovations incorporated in the SL-2000 Series.



### Features

- Photoelectric and Ionization Versions Available
- Low-flow Technology (100-4000ft/min)
- Listed for High-temp Applications
- Patented “No-tools Required”
- Patented “Test Port Valve”
- Magnet Test Capability
- Operating Voltages: 115VAC, 230VAC, 24VDC, 24VAC
- Flashing Detector LED Indicating Normal Operation
- Various Remote Accessories Available
- Green Pilot and Red Alarm Indicators
- Compatible with WP-2000 Weatherproof Enclosure
- External Mounting Tabs for Ease of Installation
- Compact and Lightweight
- Two 10A Form “C” Alarm Contacts
- One 2A Form “A” Alarm Contact
- One 10A Form “C” Trouble Contact
- Large Screw Terminals

### Listings and Approvals

- UL, CUL, CSFM and MEA Listed

## Terminal Connections

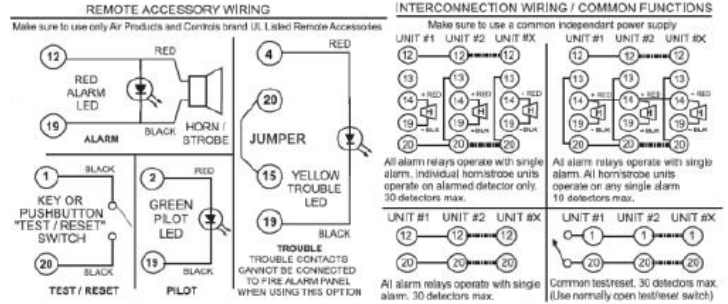
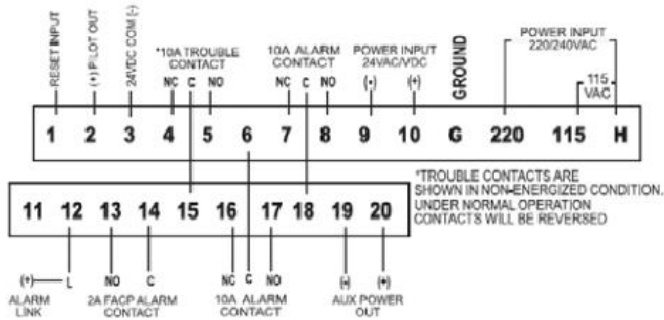

## Specification

Detector Model Number:	SL-2000-N 55000-225APO SL-2000-P 55000-328APO
Accessories:	MS- and MSR-Series Remote Accessories, WP-2000 Weatherproof Enclosure, TG-2000 Aerosol Test Gas, and T-PB Power Supplies available from Air Products and Controls Inc.)
Power Requirements: (Without Accessories)	
Standby	230VAC 8mA, 115VAC 14mA, 24VAC 55mA, 24VDC 14mA
Alarm	230VAC 18mA, 115VAC 32mA, 24VAC 190mA, 24VDC 68mA
Relay Contact Rating:	
Alarm Contacts:	Resistive load: Two form "C" rated at 10 Amps @ 115VAC Resistive load: One form "A" rated at 2 Amps
Trouble Contacts:	Resistive load: One form "C" rated at 10Amps @ 115VAC
Air Velocity:	100 to 4,000 ft./min.
Ambient Temperature:	SL-2000-N 32°F to 158°F (0 °C to 70°C) SL-2000-P 32°F to 140°F (0 °C to 60°C)
Humidity:	85 ±5 % RH (@32 ±2°C; 86 ±3.6°F) Non-condensing / Non-freezing
Wiring	Solid or stranded: #12 to #22 AWG terminals
Approvals:	UL & CUL listed (UL268A, UROX, UROX7) file # 82829, CSFM listed (3240-1004:105), MEA accepted (73-92-E; VOL. 27)
Material:	Grey plastic back box, clear plastic cover (Makrolon 94V-O)
Dimensions:	13 1/2" L x 4 1/2" W x 2 1/4" H
MAX. Net Weight:	2 1/2 lbs
Radioactive Element:	For SL-2000-N (Ionization) americium 241; 0.9 micro-curie. Do not expose to corrosive atmospheres
Hardware:	7" exhaust tube, sampling tube end cap, mounting template, test magnet, and mounting hardware included

## Order Codes and Options

SL-2000-P	Photoelectric Duct Detector, 230VAC, 115VAC, 24VAC, 24VDC
SL-2000-N	Ionization Duct Detector, 230VAC, 115VAC, 24VAC, 24VDC
STN-1.0	10" sampling tube for ducts 6" - 12" wide
STN-2.5	30" sampling tube for ducts 1' - 3' wide
STN-5.0	5' sampling tube for ducts 3' - 5' wide
STN-10.0	10' sampling tube for ducts 5' - 10' wide

[Check if this document is up to date](#) | [Give us feedback](#)

9564 Yellowhead Trail NW, Edmonton AB, T5G 0W4, Canada T: 1 (866) 462-7100 E: [info@harding-tech.com](mailto:info@harding-tech.com) W: [www.harding-tech.com](http://www.harding-tech.com)

As our policy is one of constant product improvement the right is therefore reserved to modify product specifications without prior notice.