

Axis^{AX}

Intelligent Air Duct Detectors

The Advanced Intelligent Air Duct Detectors are the latest innovation for early detection of smoke and products of combustion present in air moving through HVAC ducts in Commercial, Industrial, and Residential applications. The units are designed to prevent the recirculation or spread of smoke by air handling systems, fans, and blowers. Complete systems may be shut down in the event of smoke detection.

The operating principle of the Intelligent Air Duct Detectors is based on the Venturi effect. Two tubes extend into the HVAC duct. Air flowing through the duct is forced into the air intake (inlet) tube via the air intake holes (facing the air flow) and passes over the detector head. The air will be drawn out via the exhaust tube back into the HVAC duct. When the concentration of smoke particles suspended in the air stream reach the alarm threshold of the intelligent detector head the Intelligent Air Duct Detector will go into alarm thus alarming the Axis AX Series Intelligent Fire Alarm Control Panel.

The Intelligent Air Duct Detectors are designed to operate in duct widths from 6" to 10' wide with an air velocity between 100 to 4,000 feet per minute.

Four (4) versions of the Intelligent Air Duct Detector are available from Advanced, the versions include both two and four wire operation with an intelligent photoelectric or ionization detector. Two wire versions do not include an alarm relay contact, and can only drive a remote LED indicator. If alarm relay contact and/or additional remote accessory options are required, beyond a remote LED, the four wire version must be provided.

The Intelligent Air Duct Detectors are built to meet all local code requirements, as well as the NFPA and ICC standards regarding HVAC supply and return duct smoke detectors. Output terminals are provided for a wide range of remote accessories such as remote status indicators, and test/reset key switches or push buttons. The Intelligent Air Duct Detectors include many features that represent true innovations from current generation duct smoke detectors.

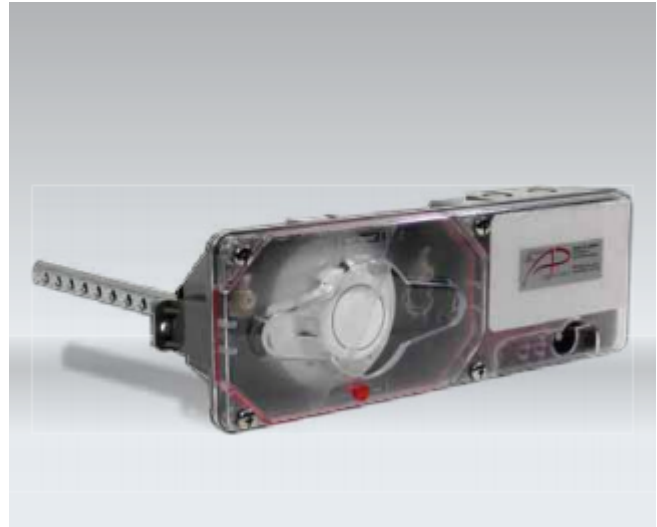

Features

- 2/4 Wire with Intelligent Photo or Ion Detector
- Low-Flow Technology (100-4000ft/min)
- Listed for High-Temp Applications
- Patented "No-Tools Required"
- Patented "Test Port Valve"
- Instantaneous Cover Removal Indication
- Staggered Terminal Blocks for Easier Wiring
- Flashing Detector LED Indicating Normal Operation

Listings and Approvals

- ETL ANSI/UL 864 Listed: 101564744NYM-001
- UL/ULC File: UROX.S2829
- CSFM Approved: 3240-1004:0116
- NYC MEA: 73-92-E

Wiring Diagram

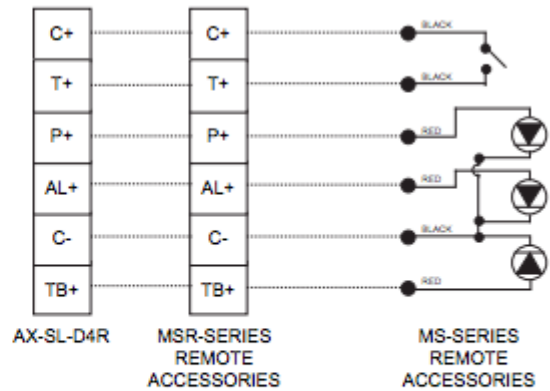
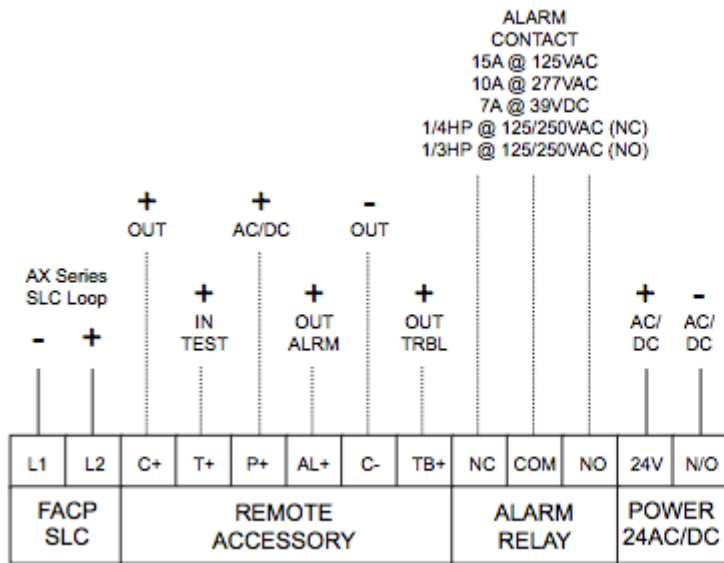

X-SL-DAA (P or N) TERMINAL CONNECTIONS AX-SL-DAA (P or N) TERMINAL CONNECTIONS

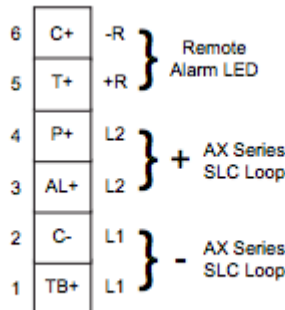

Specification

AX Series SLC Loop

Voltage	17-28 VDC
Modulation Voltage	5-9 VDC (Peek to Peek)
Supervisory Current	0.85 mA
Surge Current	2.5 mA
Alarm Current	3.5 mA (LED On) (Max.)
Line Impedance	50 Ω(Max.)
Alarm Relay Contact Rating (4-Wire Only)	
DC Voltage	7 Amp @ 39VDC
AC Voltage	15 Amp @ 125VAC, 10 Amp @ 277VAC
Wiring	Screw In-Out Terminals
Humidity	10% to 85% RH Non-Condensing
Dimensions (Diameter & Height)	13 1/2" L x 4 1/2" W x 2 1/4" D
Weight	2.25 lbs

Ambient Temperature	
AX-SL-DA4R-P, AX-SL-DAA-P	32 °-140 °F (0 °-60 °C)
AX-SL-DA4R-N, AX-SL-DAA-N	32 °-140 °F (0 °-60 °C)
Air Velocity	100 to 4,000ft/min.
Radioactive Material	
AX-SL-DA4R-N, AX-SL-DAA-N	Americium 241, 0.9 micro curie

Order Codes and Options

AX-SL-DA4R-P	Intelligent Duct Detector, PHOTO, 4-Wire
AX-SL-DA4R-N	Intelligent Duct Detector, ION, 4-Wire
AX-SL-DAA-P	Intelligent Duct Detector, PHOTO, 2-Wire
AX-SL-DAA-N	Intelligent Duct Detector, ION, 2-Wire
STN-1.0	10" Sampling Tube for Ducts 6" - 12" wide
STN-2.5	30" Sampling Tube for Ducts 1' - 3' wide
STN-5.0	5' Sampling Tube for Ducts 3' - 5' wide
STN-10.0	10' Sampling Tube for Ducts 5' - 10' wide

Check if this document is up to date | Give us feedback

9564 Yellowhead Trail NW, Edmonton AB, T5G 0W4, Canada T: 1 (866) 462-7100 E: info@harding-tech.com W: www.harding-tech.com

As our policy is one of constant product improvement the right is therefore reserved to modify product specifications without prior notice.